

902-501 / 902-501H Funball

Page 1
Rev. 08/05/2004

IMPORTANT

PLEASE READ THESE INSTRUCTIONS BEFORE COMMENCING ASSEMBLY. All equipment must be installed in accordance with these instructions. Check your shipment against Bill of Lading and Parts list. Any missing or broken parts must be reported to your distributor within 10 days of receipt of your order. When properly installed and maintained, equipment will give many years of Safe, Trouble-Free use. Periodically check for loose or broken parts. Loose bolts must be tightened and broken parts must be replaced as they can possibly create dangerous situations leading to unnecessary accidents. Resilient Surfacing should be used under all playground equipment. Appropriate publications, available at no charge, from the Consumer Product Safety Commission, include "A Handbook for Public Playground Safety". You can receive your free copy by calling 1-301-504-7908.



PACKING LIST

1	CTN			Hardware Bag
1	PIPE	1	903-501	2 7/8" OD x 9' Long
1	DOMES	1	905-501	Funball

HARDWARE BAG

1	116-804	1/2" x 1" Hex Bolt
1	316-801	1/2" Flat Washer
1	805-532	Warning Label
1	805-534	SportsPlay Label
1		Maintenance Checklist

1 CTN	1 PIPE	1 FUNBALL	3 TOTAL PCS	162 # Weight	Class 70
-------	--------	-----------	-------------	--------------	----------

SportsPlay Equipment, Inc., 5642 Natural Bridge, St. Louis, MO 63120 (314) 389-4140
www.sportsplayinc.com

GENERAL USE/FALL ZONE & FOOTING RECOMMENDATIONS

Stationary & Portable equipment - Use/Fall zones should extend a minimum of 6 feet in all directions from the perimeter of the equipment ground space. This area should be covered with the required amount of resilient safety surfacing material.

For some equipment - Use/Fall zones can overlap. See Consumer Product Safety Commission Guidelines. Diameter and depth of footings illustrated are satisfactory in most applications for pipe sizes up to 2 3/8" diameter. Varying soil & climatic conditions may require deeper and heavier footings in some areas. Check local building codes.

DETAIL-Permanent Installation Upright:

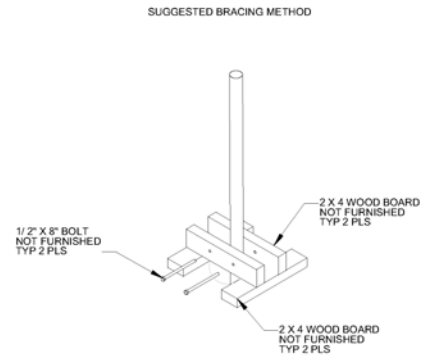
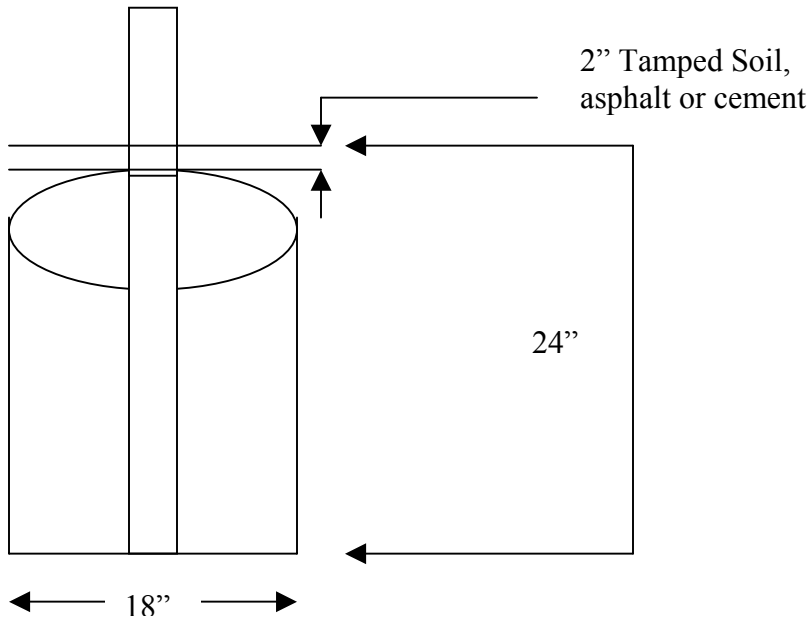

USE AREA AND FOOTING LAYOUT:

Use Zone = 30' Diameter Circle

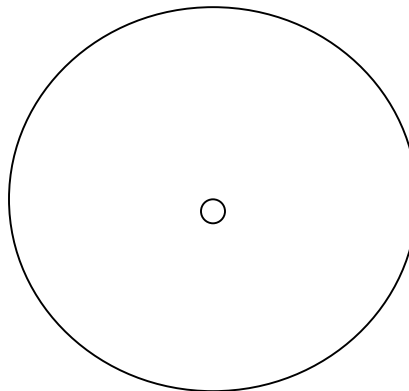

GENERAL MAINTENANCE INSTRUCTIONS:

Check MONTHLY for loose bolts, damaged or broken parts. Tighten and/or replace immediately. On swings and any equipment that uses S-hooks and/or Swing Hangers check the bearing surfaces for wear. Replace any parts that show a reduction of 25% from the original size.

ASSEMBLY AND INSTALLATION:

NOTE: All threaded ends of bolts protruding beyond nuts must be cut off and/or peened to eliminate sharp edges. No more than two threads should extend beyond face of nut. All washers, "T" nuts, and other fastener hardware used on round pipe or tubing must be hammered down to conform to the curved underlying surface to eliminate catch points. DO NOT tighten nuts more than hand-tight until entire assembly is completed.

Playing surface may be dirt, resilient surfacing, concrete or asphalt.

STEP #1: Dig footing hole 18" x 24" deep.

STEP #2: Locate ½" bolt. Insert the end of the pole that has the retaining plate into cavity until it stops against the funball plastic. Place the flat washer onto bolt and insert in through the hole at the bottom of the funball plastic assembly, then into the retaining plate on top of the pole. Using a flat or box-end wrench, tighten the bolt snugly. DO NOT OVERTIGHTEN.

STEP #3: Stand the pole in the center of the footer hole. Plumb and level. Brace into position. Fill hole with concrete to within 2 " of the top. Be sure to 'cone' top of concrete for drainage if unit will be installed with a dirt playing surface.

STEP #4: Let the concrete set for 3 days. Remove bracing. Fill the remaining 2" in the hole with soil and tamp - or cover with cement or asphalt surfacing to match existing surface.

Make sure that the concrete footing has NO exposed concrete.

STEP #5: Attach warning label and Manufacturer's Identification label to a clean surface. The labels should be attached in a location where they are clearly visible and legible and away from normal hand and foot placement areas. The labels must be replaced if they become illegible, destroyed or removed. Contact your SportsPlay distributor for replacements.

Maintenance:

Periodically check product hardware and for structural integrity. Tighten any hardware that may have become loose and if any defects are found, discontinue use and contact your distributor.