

511-301 CORRAL MINI-COURSE

*** IMPORTANT ***

PLEASE RETAIN THIS INSTRUCTION SHEET IN YOUR FILES. IT CONTAINS IMPORTANT REPLACEMENT PARTS INFORMATION. ALL EQUIPMENT SHOULD BE INSTALLED IN ACCORDANCE WITH THESE INSTRUCTIONS.

IT IS IMPORTANT TO USE AND MAINTAIN ALL PUBLIC PLAYGROUND EQUIPMENT PROPERLY. PLAYGROUND EQUIPMENT WHICH IS IMPROPERLY MAINTAINED CAN CAUSE SERIOUS INJURY. PERIODICAL INSPECTIONS, MAINTENANCE, REPAIR AND/OR REPLACEMENT OF DAMAGED PARTS IS NECESSARY FOR SAFE OPERATION OF EQUIPMENT AND SAFETY OF USERS. RESILIENT SURFACING SHOULD BE USED UNDER ALL PLAYGROUND EQUIPMENT. APPROPRIATE PUBLICATIONS, AVAILABLE AT NO CHARGE, FROM THE CONSUMER PRODUCT SAFETY COMMISSION, INCLUDE "A HANDBOOK FOR PUBLIC PLAYGROUND SAFETY." YOU CAN RECEIVE YOUR FREE COPY BY CALLING 1-301-504-7908.

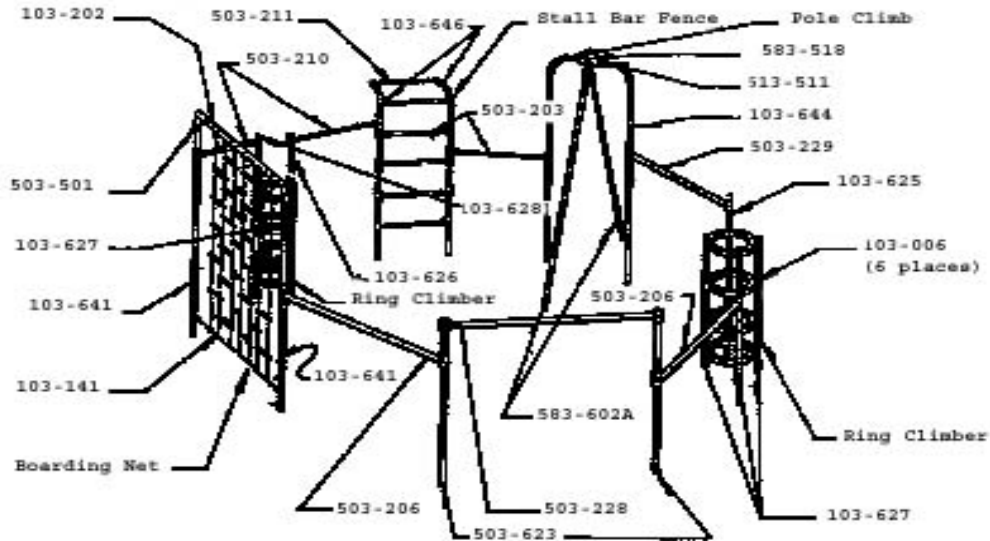

PACKING LIST

1 CTN	-	1 Hardware Bag
	-	1 103-141 Net
	-	2 503-501 Elbow
	-	4 513-511 Adaptor
	-	1 583-518A Center Fitting
1 CTN	-	8 103-006 Ring
1 BDL	-	2 103-641 Post
	-	1 103-202 Net Bar
1 BDL	-	1 503-211 Turning Bar
	-	2 503-210 Turning Bar
1 BDL	-	2 503-206 Turning Bar
1 BDL	-	1 503-228 Turning Bar
	-	1 503-229 Turning Bar
1 BDL	-	2 503-623 Post
1 BDL	-	1 103-625 Post
	-	1 103-626 Post
1 BDL	-	6 503-203 Turning Bar
1 BDL	-	4 103-627 Post
1 BDL	-	1 103-627 Post
	-	1 103-628 Post
2 PIPE	-	2 103-646 Sliding Pole
2 PIPE	-	2 103-644 Sliding Pole
2 PIPE	-	2 583-602A 1 7/8" x 13'-0" Leg

HARDWARE BAG

5	-	105-016	1 7/8" Alum Pipe Plug
9	-	585-901	S-Hook
34	-	196-803	1/2" x 3/4" Socket Set Screw
32	-	116-550	5/16" x 3" Button Hd Bolt
34	-	216-512	5/16" Button Hd Nut
32	-	326-501	5/16" Lock Washer
2	-	416-350	3/16" Socket Key
1	-	416-400	1/4" Socket Key
2	-	805-532	Warning Label
2	-	805-534	Sportsplay Label
1	-		Maintenance Checklist

2 CTNS	9 BDL	6 PIPE	17 TOTAL PCS	WT 495#	CLASS 70
--------	-------	--------	--------------	---------	----------

511-301 CORRAL MINI-COURSE

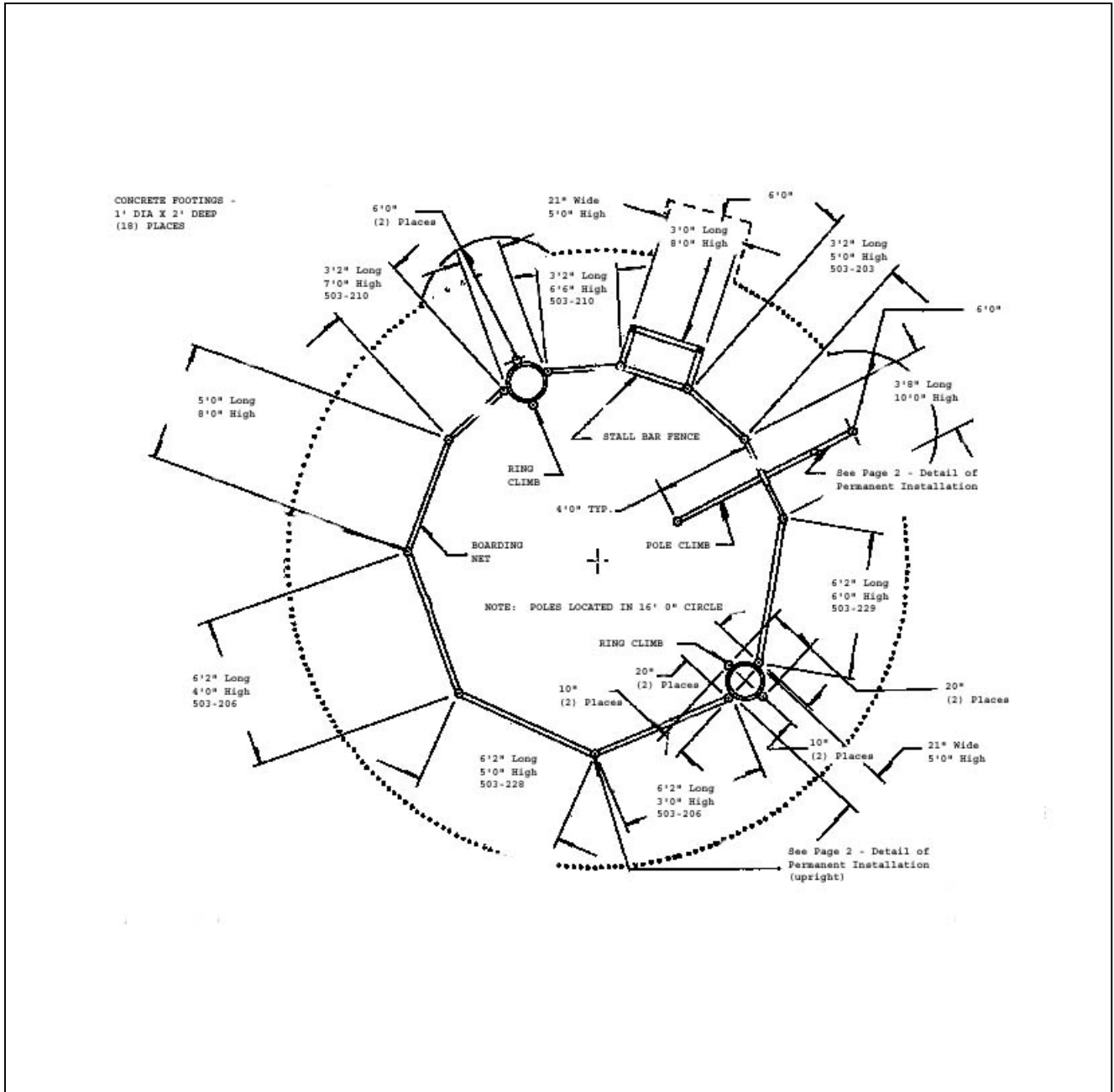

511-301 CORRAL MINI-COURSE

Page 3 of 3
Rev 4/8/04

GENERAL USE/FALL ZONE & FOOTING RECOMMENDATIONS

STATIONARY & PORTABLE EQUIPMENT - USE/FALL ZONES SHOULD EXTEND A MINIMUM OF 6 FEET IN ALL DIRECTIONS FROM THE PERIMETER OF THE EQUIPMENT GROUND SPACE. THIS AREA SHOULD BE COVERED WITH THE REQUIRED AMOUNT OF RESILIENT SAFETY SURFACING MATERIAL. FOR SOME EQUIPMENT - USE/FALL ZONES CAN OVERLAP. SEE CONSUMER PRODUCT SAFETY COMMISSION GUIDELINES. DIAMETER & DEPTH OF FOOTING ILLUSTRATED ARE SATISFACTORY IN MOST APPLICATIONS FOR PIPE SIZES UP TO 2 3/8" DIAMETER. VARYING SOIL & CLIMATIC CONDITIONS MAY REQUIRE DEEPER & HEAVIER FOOTINGS IN SOME AREAS. CHECK LOCAL BUILDING CODES.

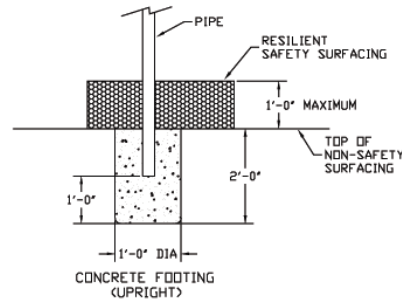
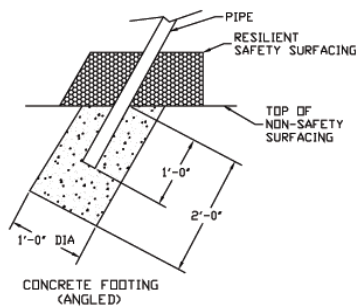

* If resilient surfacing is to be less than 12", then additional pipe should be put in concrete to maintain proper finish grade for equipment.

**SEE PAGE 2 FOR FOOTING LAYOUT
DIAGRAM**

511-301 CORRAL MINI-COURSE

Page 4 of 4
Rev 4/8/04

GENERAL ASSEMBLY INSTRUCTIONS:

Check all the parts and hardware with the packing list to be sure you have received everything needed to assemble this product. CONTACT YOUR LOCAL DISTRIBUTOR WITH NOTIFICATION OF ANY MISSING OR DAMAGED PARTS. Contact must be made within ten days of receipt of your order.

Only hand-tighten nuts & bolts on initial assembly. Final tightening should be done EVENLY after final assembly when unit has been plumbed & leveled. After assembly is complete, ANY ENDS OF BOLTS PROTRUDING BEYOND NUTS SHOULD BE CUT OFF AND/OR PEENED OVER TO REMOVE ANY SHARP EDGES. Go over entire unit to file smooth any sharp edges or projections that may have been caused by rough handling in shipping or installation. T-Clamps are designed for both one and two bolt connections. In many situations only one bolt is required. See specific assembly instructions. On products with platforms install 1 - 2 degrees off level to facilitate water drainage.

GENERAL MAINTENANCE INSTRUCTIONS:

Check MONTHLY for loose bolts, damaged or broken parts. Tighten and/or replace immediately.

SPECIFIC ASSEMBLY INSTRUCTIONS:

- NOTE: All threaded ends of bolts protruding beyond nuts must be cut off and/or peened to eliminate sharp edges. No more than two threads should extend beyond face of nut.
All washers, "T" nuts, and other fastener hardware used on round pipe or tubing must be hammered down to conform to the curved underlying surface to eliminate catch points.
- STEP #1: Dig footing holes as per layout on PAGE #3.
- STEP #2: Assemble 4-Ring Ladder with two high turning bars. SEE DETAIL A. Cast aluminum rings have molded ejection marks on the BOTTOM side. Brace in footing holes at proper height for depth of resilient surfacing to be used.
- STEP #3: Assemble Boarding Net. SEE DETAIL B. Slide Turning Bars (503-2510 & 503-206) onto legs of Boarding Net before positioning & bracing in footing holes.
- STEP #4: Slide Turning Bar (503-210) up & attach to top of Ring Ladder Post. Height can be adjusted down if desired by cutting off some of the ladder post. SEE DETAIL C for suggested Turning Bar heights.
- STEP #5: Slide Post (103-648) thru sleeve of other Turning Bar attached to Boarding Net. Brace post in footing hole & set turning bar at desired height. SEE DETAIL C.
- STEP #6: Skip to other 4-Ring Ladder. Assemble as in STEP #1, positioning Turning Bar (503-206) between middle two rings as shown. Brace in footing hole. Attach Top Turning Bar (503-229) between two Posts (103-648).
- STEP #7: Go back & put on other Post (103-648). Slide thru other end of Turning Bar Sleeve attached to Ring Climber. Brace in footing hole. Attach Top Turning Bar (503-228) between two Posts (103-648).
- STEP #8: Assemble right half of Pole Climb. SEE DETAIL D. Slide Turning Bar Sleeved (503-229) thru Pole Climb Leg. Brace in footing holes. Attach Turning Bar to top of Ring Climber Post.
- STEP #9: Assemble Stall Bar Fence. SEE DETAIL E. Slide Turning Bars (503-203 & 503-210) onto Stall Bar Fence Legs so that they will be in proper position as per overall sketch on PAGE #1. Brace in footing holes. Attach Turning Bar (503-210) to top of Ring Ladder Post.
- STEP #10: Slide other Pole Climb Leg thru sleeve of Turning Bar (503-203). Brace in footing holes & attach to rest of Pole Climb Assembly.
- STEP #11: Plumb & level entire unit. Tighten all nuts & bolts so that lock washers are flat. Pour Concrete. Wait 48 hours before removing braces, driving

511-301 CORRAL MINI-COURSE

pipe plugs into open ends of pipe posts on Ring Climbers, installing resilient surfacing & using equipment.

STEP #12: Attach Warning Label and Manufacturer's Identification Label to a clean surface. The Labels should be attached in a location where they are clearly visible and legible and away from normal hand and foot placement areas. The Labels must be replaced if they become illegible, destroyed or removed. Contact your distributor for replacement Labels.

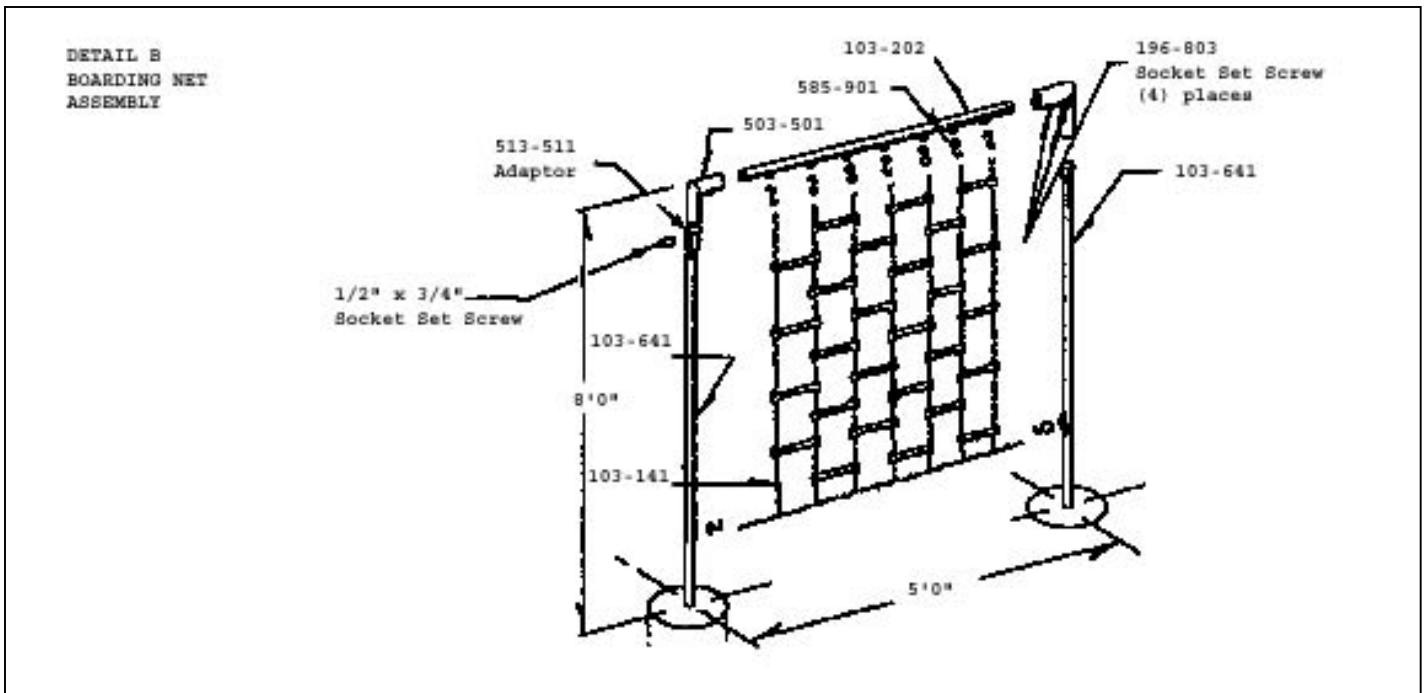
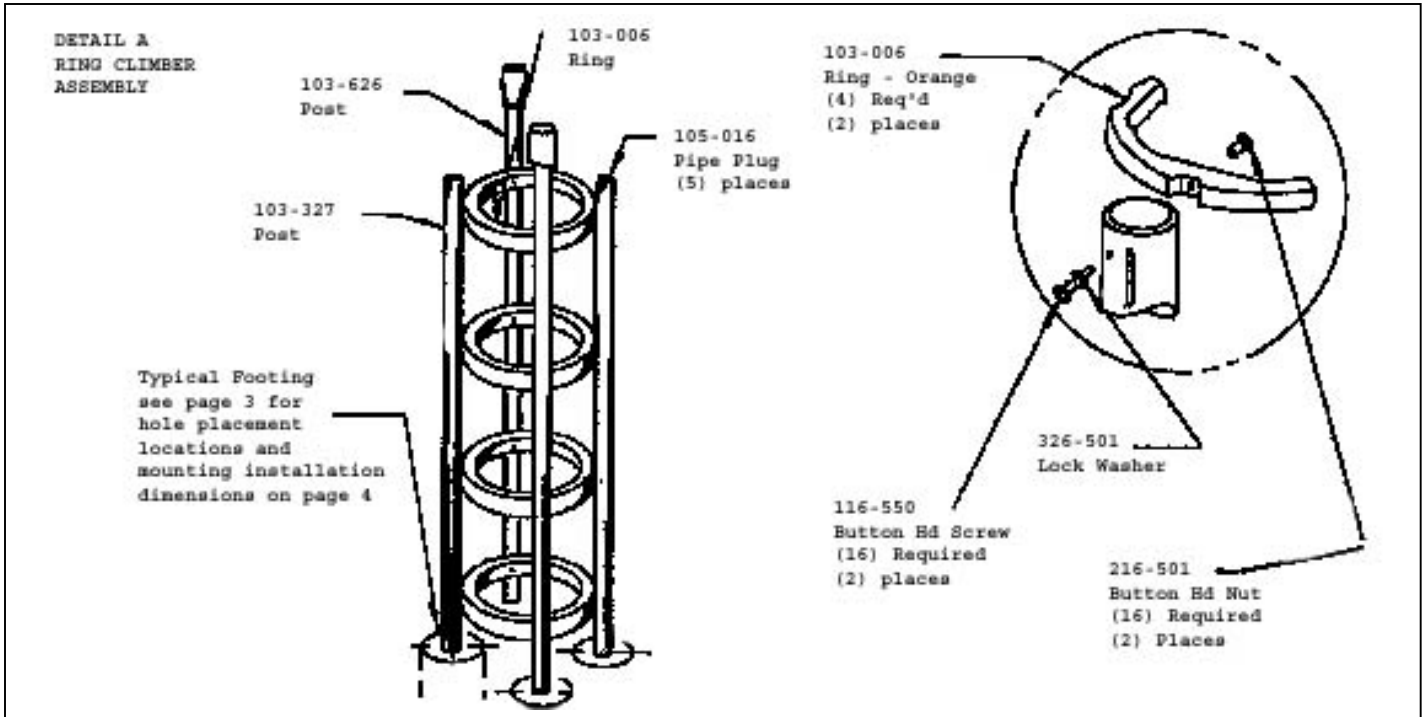

511-301 CORRAL MINI-COURSE

DETAIL C

* THE FOLLOWING TURNING BARS SHOULD BE LOCATED AT THE SUGGESTED HEIGHT CALLED OUT FOR EACH OF THEM BELOW.

USING PAGES 1 AND 2 FOR A VISUAL AID FOR POSITIONING EACH PARTICULAR PART NO. AND RESPECTIVE LOCATION SHOULD BE EMPLOYED FOR THE FOLLOWING EXERCISES.

<u>PART NO.</u>	<u>LOCATION</u>	<u>SUGGESTED HT.</u>
503-206	BETWEEN 513-603, BOARDING NET POST AND 103-648, POST	4' 0"
503-228	BETWEEN 103-648, POSTS (2) PLACES	5' 0"
503-206	BETWEEN 103-648, POST AND RING CLIMB POST, PART NO. 103-627	3' 0"
503-229	BETWEEN KING CLIMB POST, PART NO. 103-625 AND POSE CLIMB ASSEMBLY	6' 0"
503-203	LOCATION SHOWN ON PAGE 2 OF THIS DOCUMENT	5' 0" REF
503-210	BETWEEN STALL BAR FENCE AND POST PART NO. 103-626	6' 6"
503-210	BETWEEN RING CLIMB POST PART NO. 103-628, AND BOARDING NET ASSEMBLY.	7' 0"

AFTER LOCATING EACH TURNING BAR CALLED OUT ABOVE AT THE SUGGESTED HEIGHT, SECURE EACH BAR TO RESPECTIVE STRUCTURE USING 196-803, SOCKET SET SCREWS. HAND-TIGHTEN USING ¼" SOCKET KEY. 416-400.

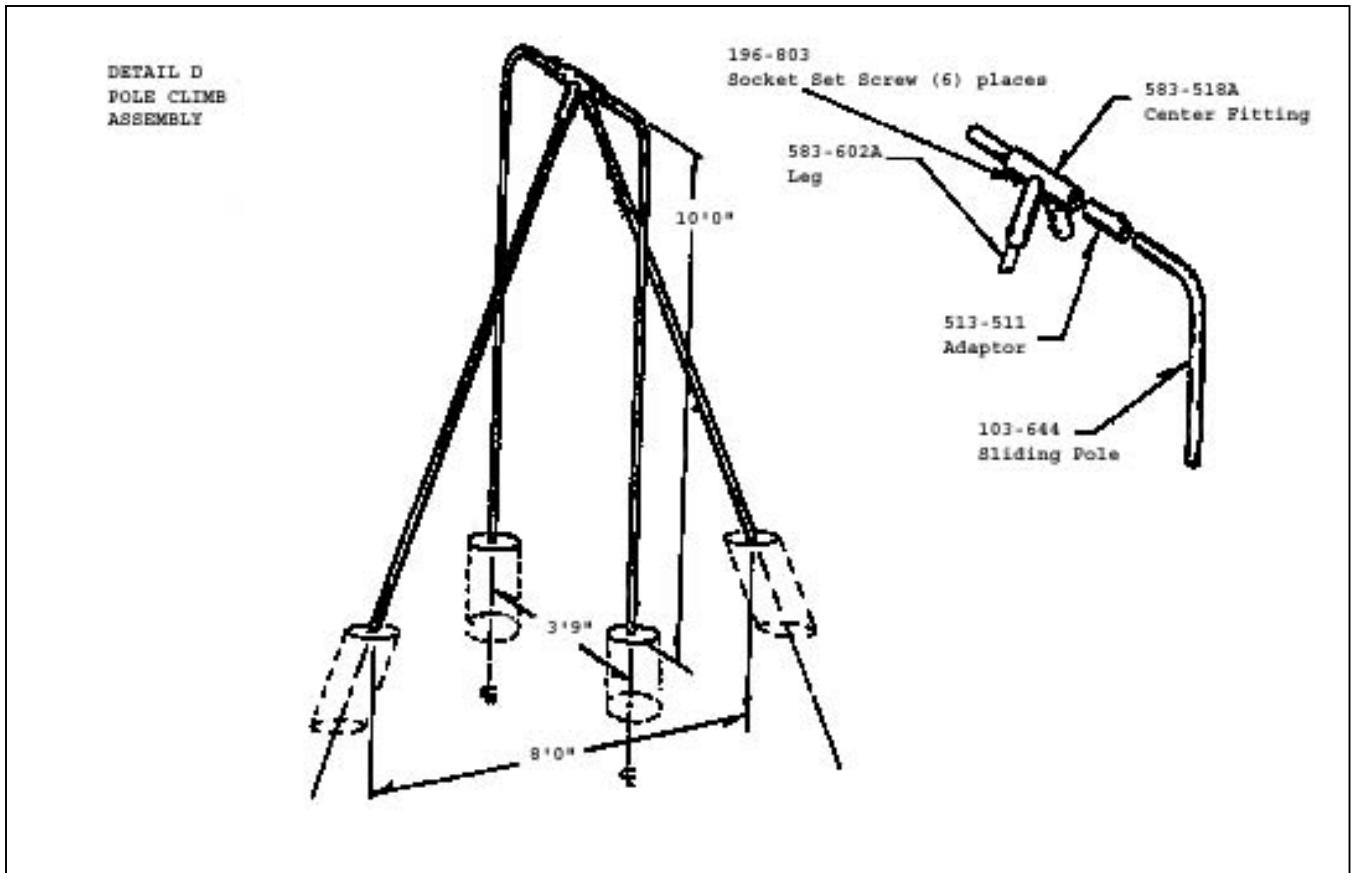

511-301 CORRAL MINI-COURSE

