

**5" ARCH SWING FRAME
8' - 1 BAY
#90015501XX**

USER GROUP: 2 - 12

RECOMMENDED CREW: 2 people

TOOLS REQUIRED:

1/4" Allen Head Tool

Level

Tape measure

Auger / Post hole digger / Shovel

High speed 3/8" electric drill *w/clutch*

NOTE: Use of any other driver may result in damage to tool and/or hardware!

INSTALLATION TIME: 1 Hour

CONCRETE REQUIRED: 14.12 Cubic Feet

NOTE: Concrete must have a minimum rating of 2,500 psi and must be mixed per manufacturer's recommendations.

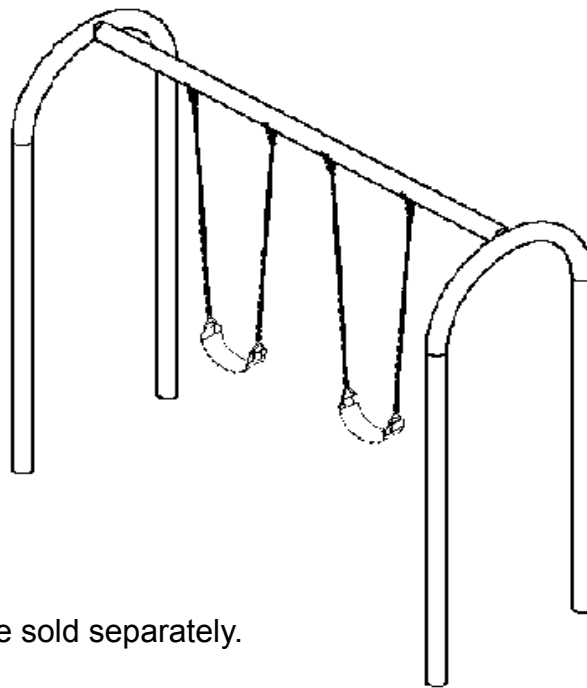

NOTE:

Swing chains and seats are sold separately.

PRE-INSTALLATION CHECK:

Compare all items received to the packing list. Notify your local sales representative immediately if any parts are missing or damaged.

**We are not responsible for items discovered missing
after 72 hours from time of delivery!**

Before beginning installation, make sure that you have read and understand the Installation Introduction manual that was supplied to you. If you did not receive a copy, or if you have a question regarding anything covered in this manual, contact your local sales representative.

INSTALLATION GUIDELINES

STEP 1

Refer to PLAN VIEW and FOOTING LAYOUT to locate position of swing frame.

STEP 2

Excavate footing as shown in FOOTING LAYOUT and FOOTING DETAIL. Place a 2" spacer block in the bottom of each hole.

STEP 3

Select arched swing frame ends, top bar and four set screws. Set swing frame ends into place in footing holes and brace into position. Slide top bar over swing frame end stubs and hold top bar in place with pre-drilled holes and nuts at the 6:00 position. Secure using two set screws. Repeat for other end (see Detail A).

Detail A

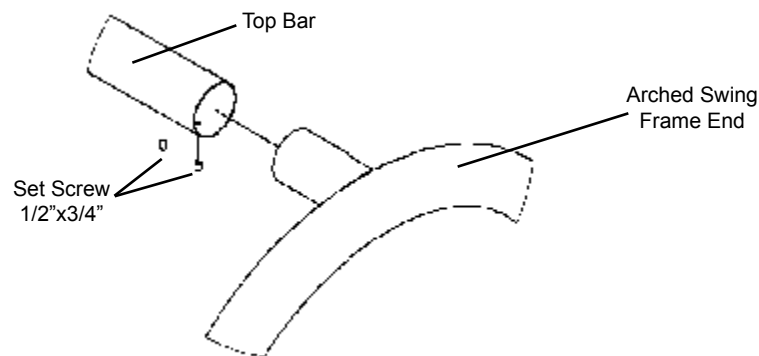

STEP 4

Verify that swing frame is level and plumb in footings and that it is at correct height. **NOTE:** Center of top rail needs to be 96" above finished surfacing. Pour concrete in footings to correct level. **NOTE:** Concrete must have a minimum rating of 2,500 psi and must be mixed per manufacturer's recommendations. Fill remainder of hole with dirt. Allow concrete to harden for at least 48 hours before use! For safety reasons, do not attach swing chains or seats to swing frame until playground is ready to open. **NOTE:** Swing seats and chains sold separately.

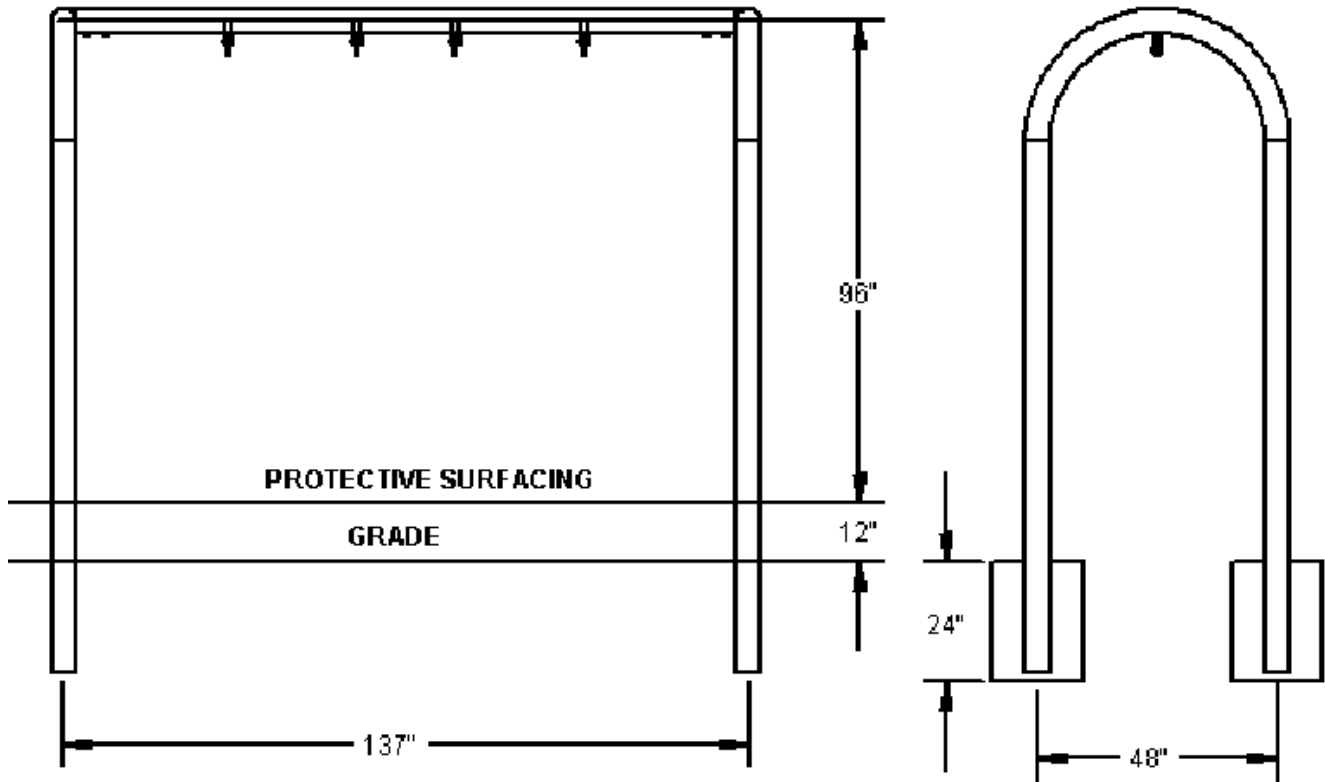

ELEVATION VIEW

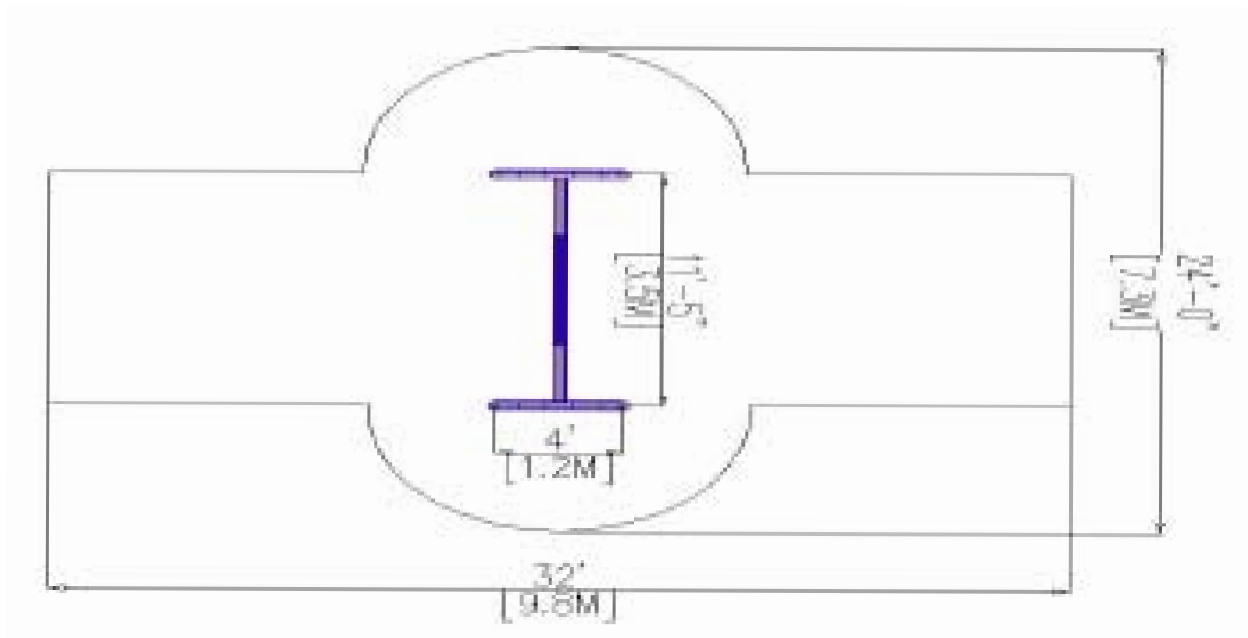

FOOTING LAYOUT and USE ZONE

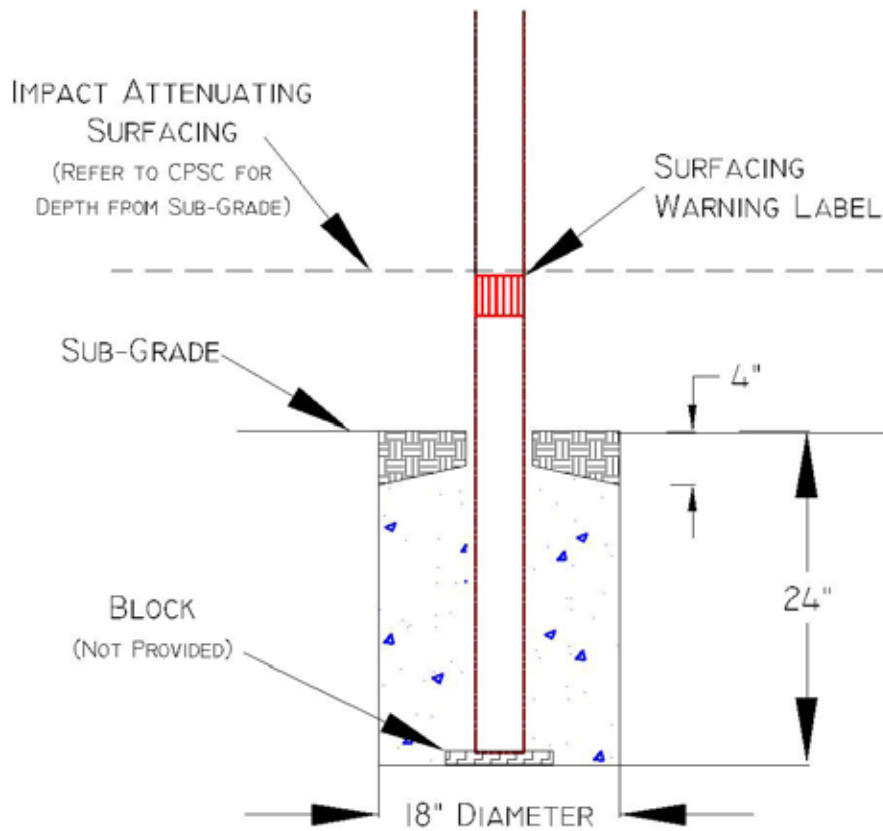

FOOTING ELEVATION